

# RITEC MSC COMPACT CIRCULAR SCREEN SEPARATOR HIGH SCREENING CAPACITY WITH MINIMUM HEADROOM REQUIREMENTS CENTRAL FEEDING AND DISCHARGING

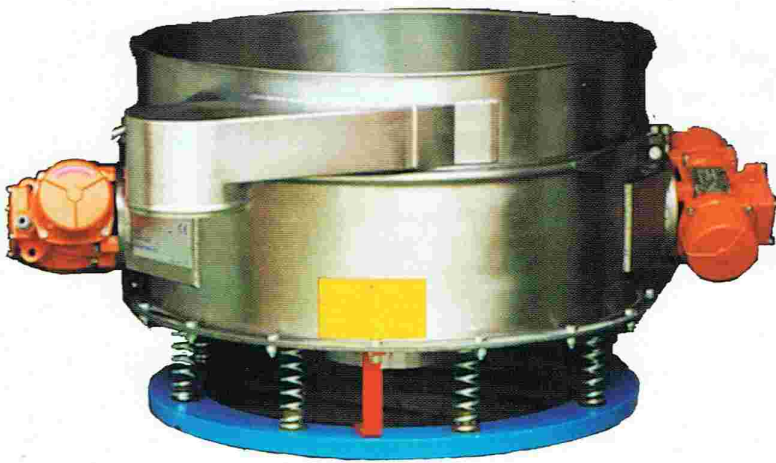

**MSC 900**



**MSC 600**

RITEC MSC single desk circular screen separator is available in 400 mm, 600 mm, 900 mm, 1200 mm and 1500 mm diameter. Construction in stainless steel 304 or 316 or carbon steel – optionally electro polished.

The RITEC MSC circular screen separator is designed for processing operations where overhead space is minimal and when feeding inlet and product discharge outlet needs to be on the same centerline. MSC Separators are easy to incorporate in existing process.

By having dual outboard motors externally attached on the rim of the machine desk, this separator is designed for high scalping capacity.

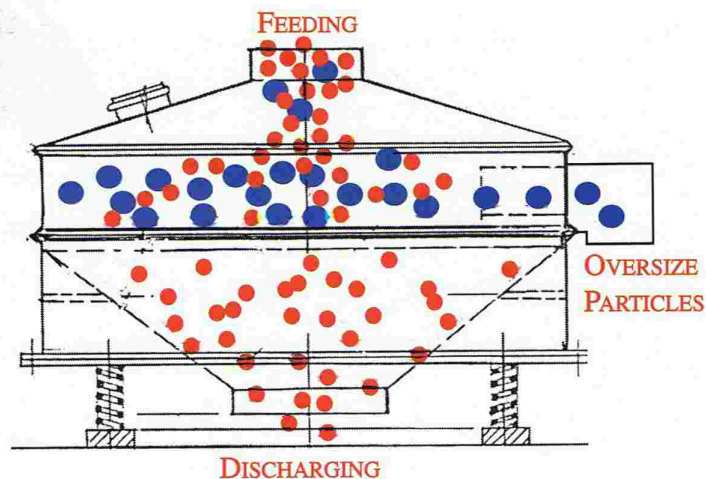

# RITEC

Zone d'activités de Signes, Avenue de Rome – BP 30718, F-83030 TOULON Cedex 9 (France)  
Tel : +33 (0)4 94 88 30 37 – Fax : +33 (0)4 94 90 39 65 - Email : [ritec@wanadoo.fr](mailto:ritec@wanadoo.fr) - Site : [www.ritec.fr](http://www.ritec.fr)

## ADVANTAGES

- Compact design, minimum height requirement.
- Exceptionally high capacity for solid/solid or liquid/solid classification.
- The dual outboard motors mounted at the desk periphery allow to control the amplification of vibrations and thus the speed of particles across and through the screen – Central location of the inlet and the outlet. Oversize particles laterally cleared.
- Maintenance procedures and specific vibration adjustments are greatly simplified due to the external position and easy access of the motors.

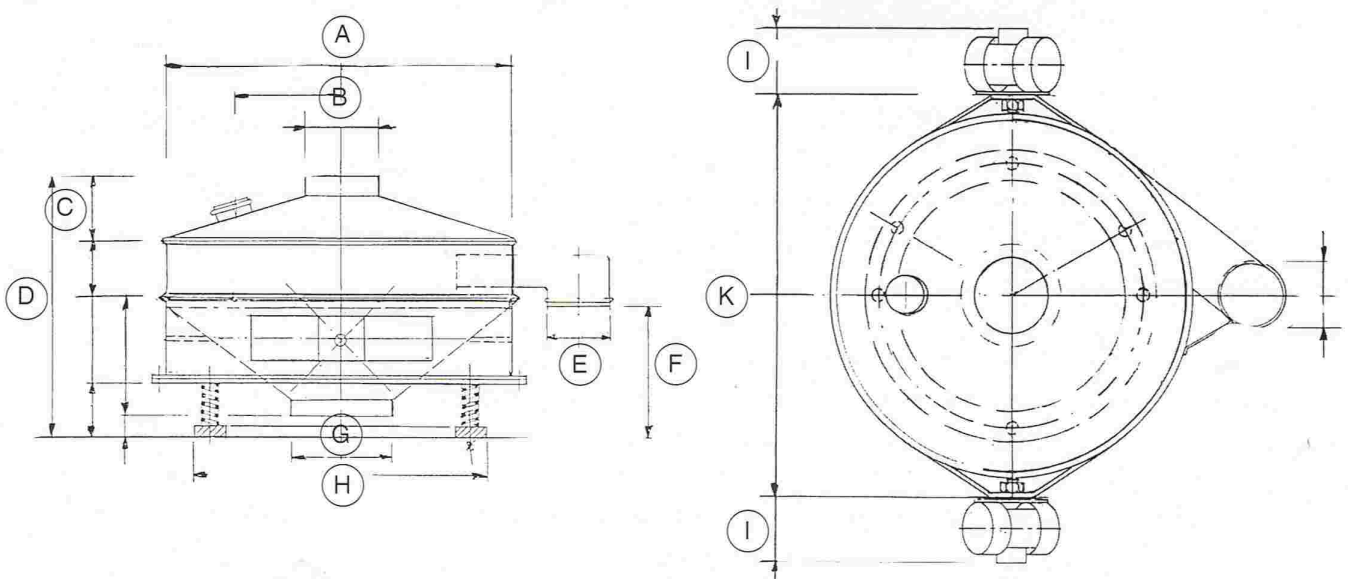

TYPE	Ø	A	B	C	D	E	F	G	H	I	K	S(m <sup>2</sup> )	P(w)
MSC 16	400	ø 450	ø 100	105	590	ø 80	305	ø 200	ø 400	150	490	0,1	85
MSC 24	600	ø 650	ø 125	165	650	ø 127	305	ø 250	ø 590	150	700	0,255	300
MSC 36	900	ø 900	ø 204	205	837	ø 204	425	ø 250	ø 810	175	980	0,528	300
MSC 48	1200	ø 1200	ø 250	205	837	ø 204	440	ø 350	ø 982	175	1288	1,02	525
MSC 60	1500	ø 1510	ø 250	207	1030	ø 250	565	ø 400	ø 1140	210	1550	1,651	525

OUR TEST CENTER IS AT YOUR DISPOSAL FOR TRIALS

# RITEC

Zone d'activités de Signes, Avenue de Rome – BP 30718, F-83030 TOULON Cedex 9 (France)  
 Tel : +33 (0)4 94 88 30 37 – Fax : +33 (0)4 94 90 39 65 - Email : [ritec@wanadoo.fr](mailto:ritec@wanadoo.fr) - Site : [www.ritec.fr](http://www.ritec.fr)

## SPECIAL DESIGNS

### VIBRATING SIEVE MACHINE MC with bag-emptying, on rollers

- Dust extraction chimney.
- Safety grid, easy dismantling of the rods for quick cleaning.
- Compact design
- Low noise operating



### SIEVE MACHINE IN PHARMA VERSION



Sieve machine TN Ø600mm  
in stainless steel 316L,  
glue and seals FDA,  
Atex zones 2/22



Sieve machine MC Ø400mm  
central inlet and outlet,  
in stainless steel 316L, mirror polishing  
glue and sealsFDA,  
Atex zones 1/21 or 2/22



Tél +33 (0)4 94 88 30 37  
Fax +33 (0)4 94 90 39 65

ZI deSignes, Av de Rome  
BP 30718  
F-83030 TOULON cedex 9 / France

Web : [www.ritec.fr](http://www.ritec.fr) Email : [ritec@wanadoo.fr](mailto:ritec@wanadoo.fr)